

Decoding the 2026 HVAC Replacement Quote

A diagnostic guide to navigating costs, evaluating contractors, and investing in your home's custom mechanical system.

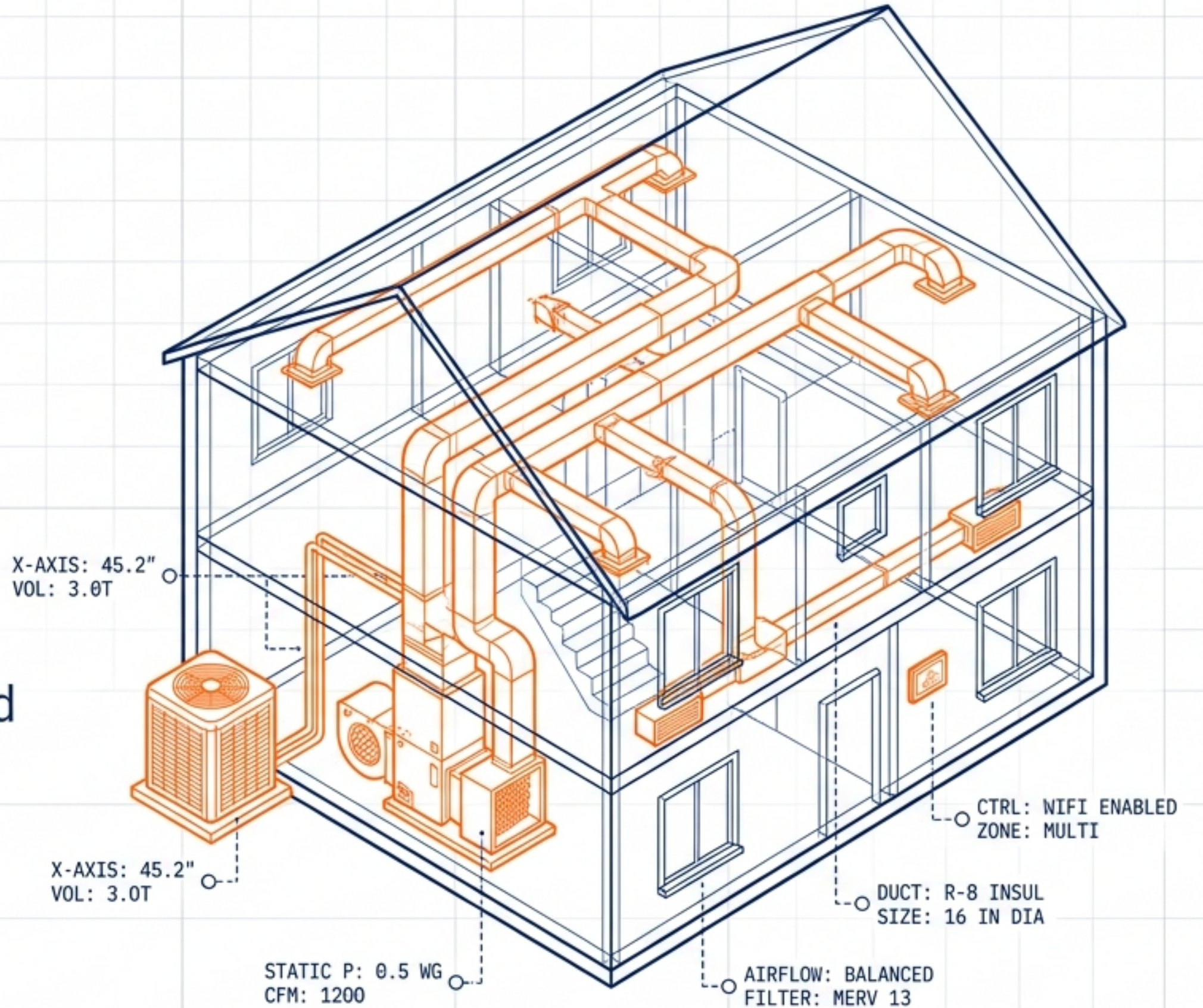

HVAC replacement is one of a home's most expensive and least understood investments.

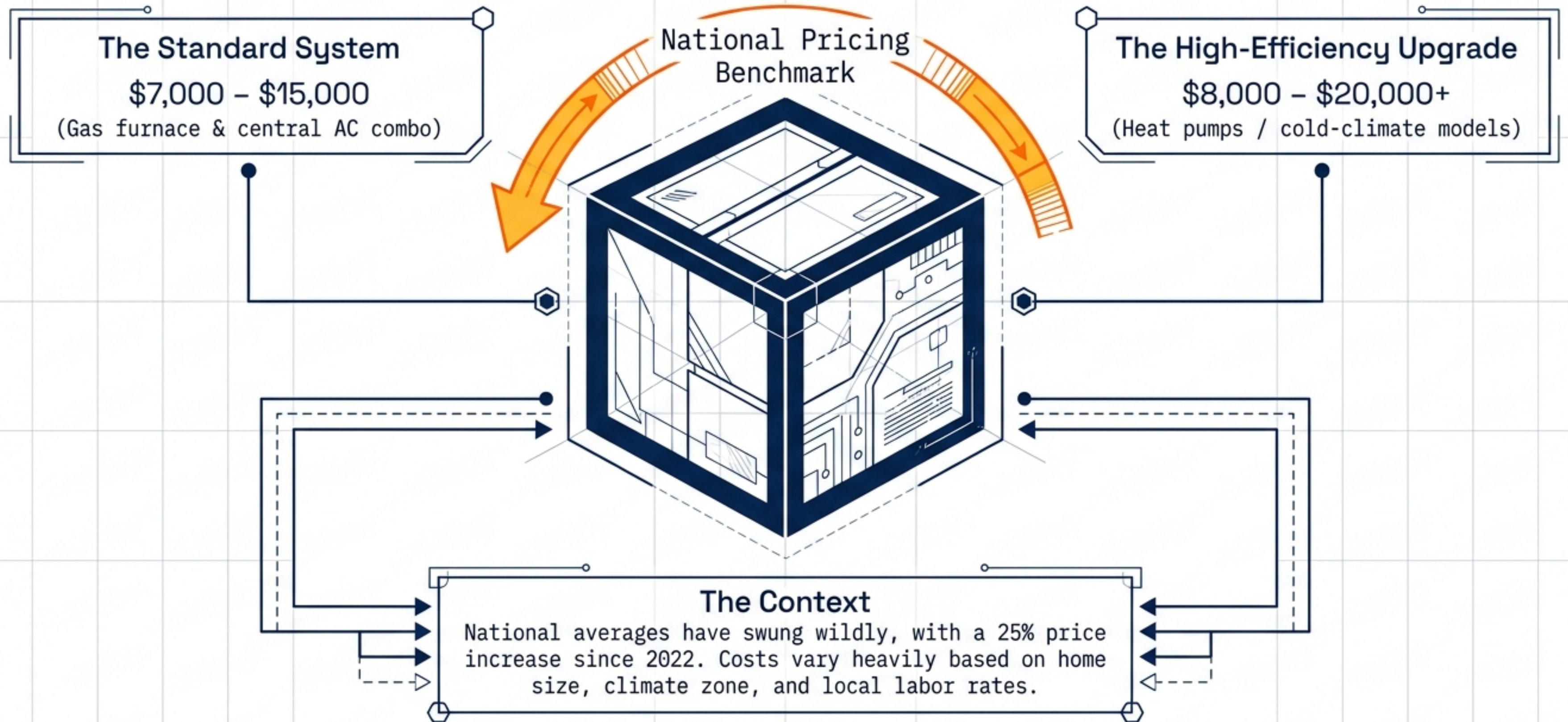

System costs scale dramatically based on home footprint, climate zone, and technology tier.

2026 Real-World Projects Matrix

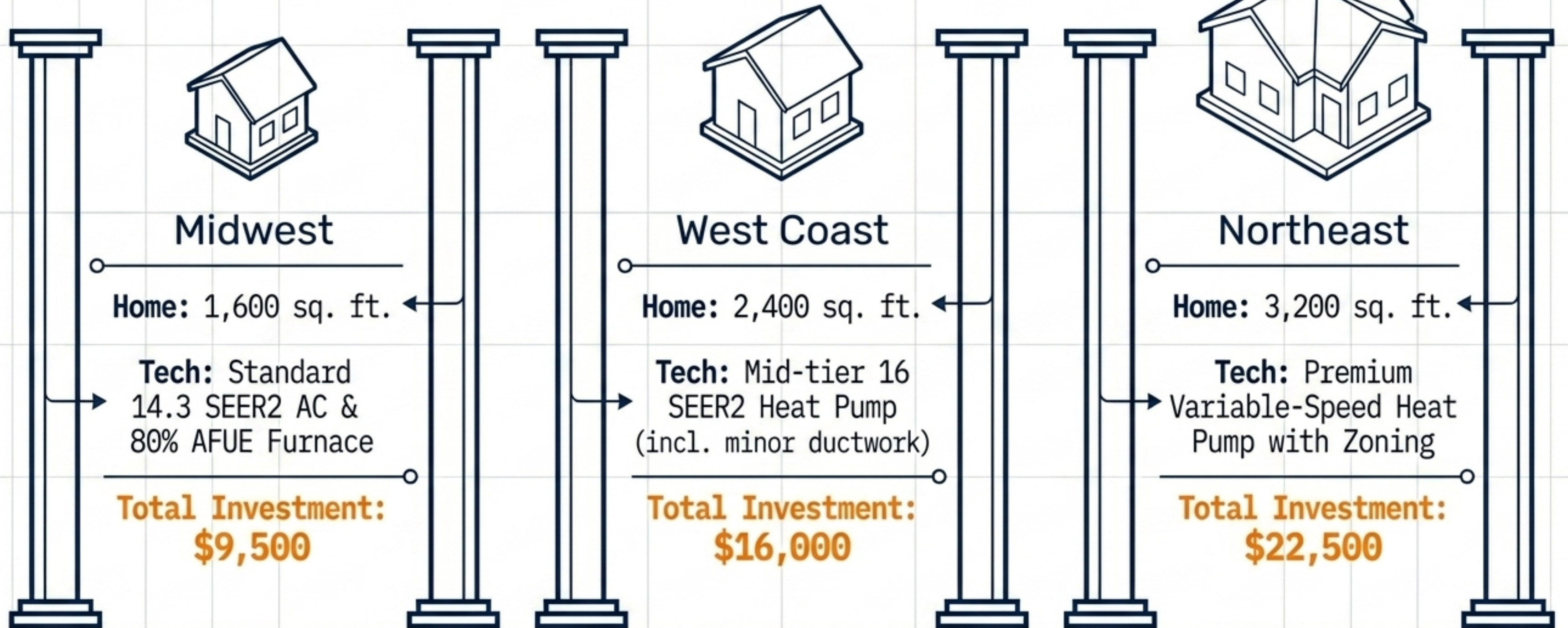

Searching for equipment prices online creates a fundamentally false baseline for your project.



The Illusion:
Treating an HVAC system like a plug-and-play appliance (like a refrigerator) from a big-box store.

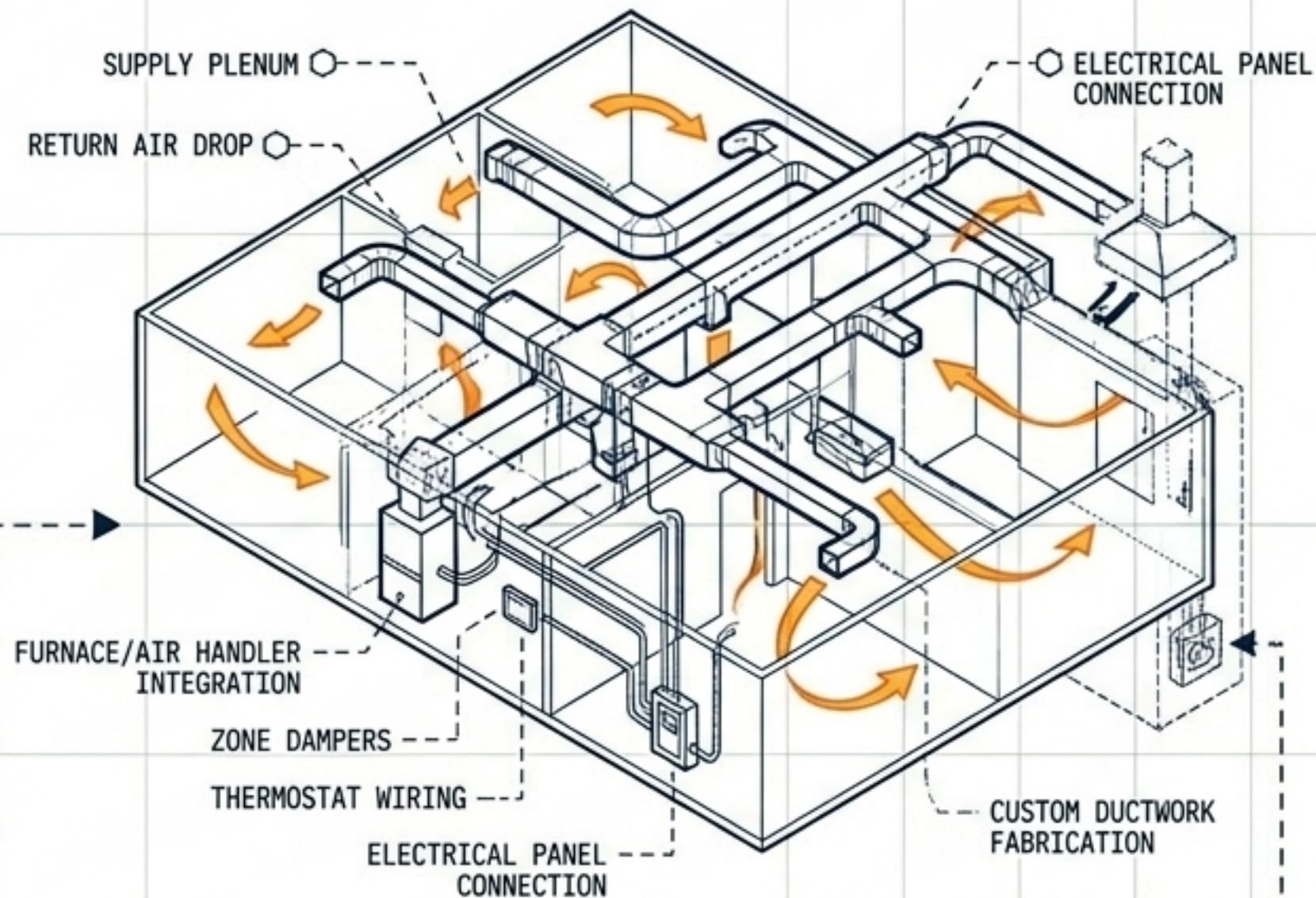

The Reality:
The physical unit accounts for only 40% to 50% of the total project cost. The remainder is not "pure profit"—it is the cost of engineering a custom life-support system for your home.

The true cost of installation reflects specialized labor, operational scale, and custom engineering.

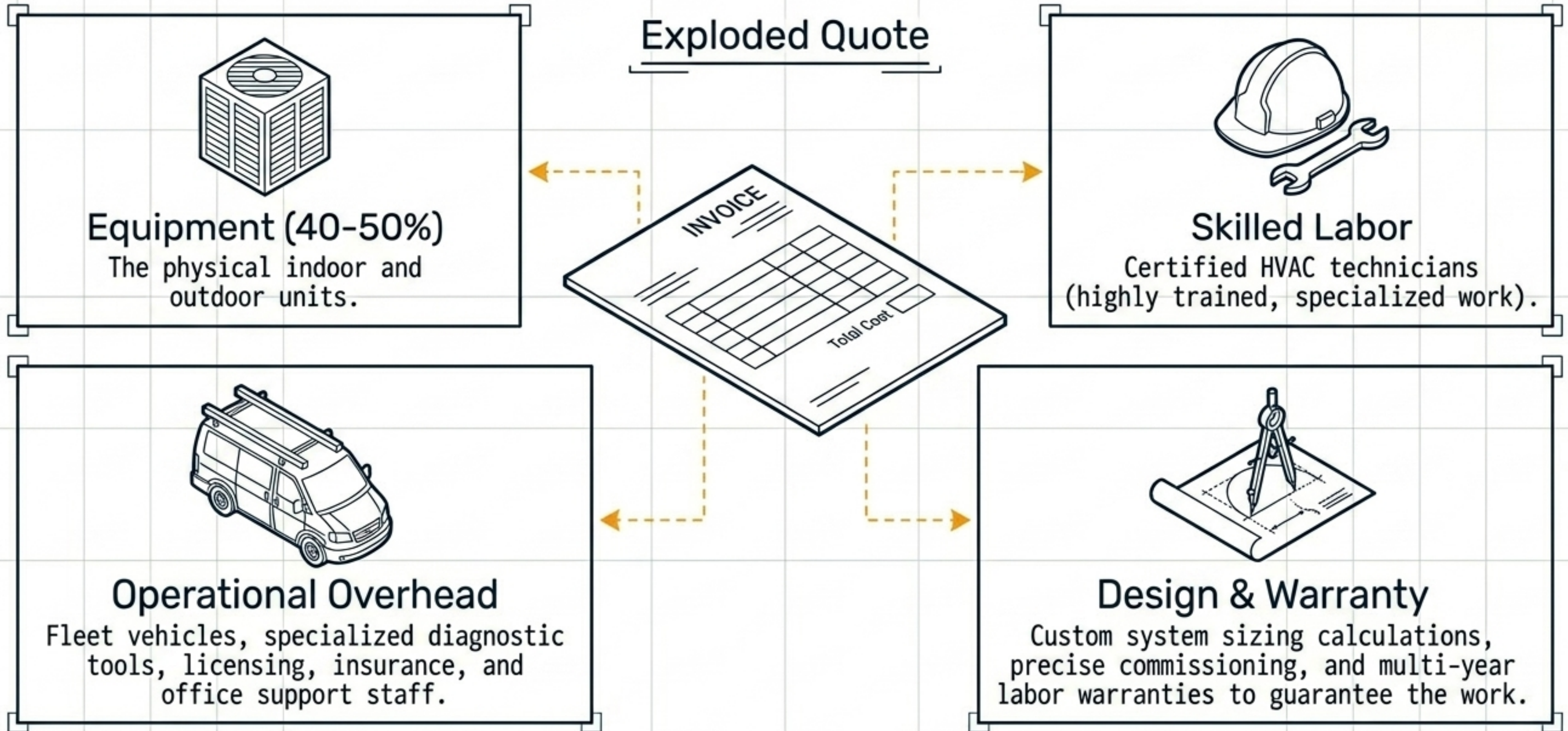

Pairing a modern air conditioner with an aging furnace
furnace bottlenecks your system's efficiency.

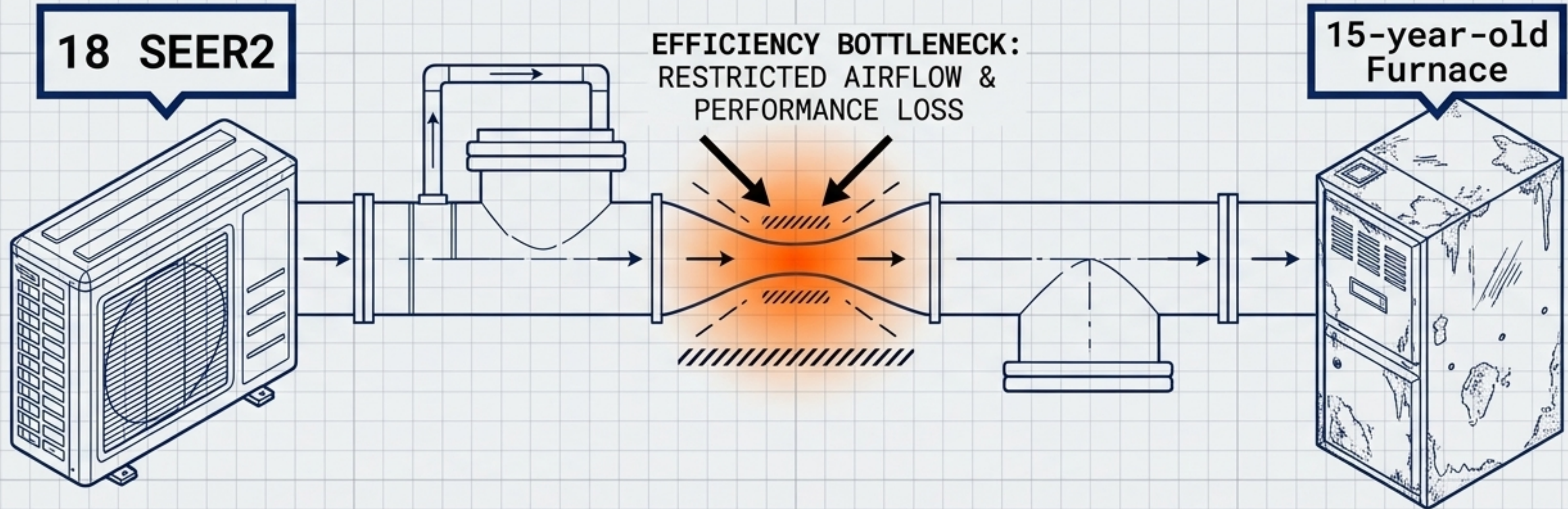

The Matched Set

To achieve advertised SEER2 efficiency, indoor and outdoor units must be a manufacturer-certified pairing.

Labor Efficiency

Replacing both simultaneously saves significant labor hours compared to paying for two separate jobs, as setup, access, and testing overlap.

Three external market forces are actively reshaping the baseline cost of modern installations.

Forces Shaping Your Quote

Federal Policy

The Inflation Reduction Act (IRA) offers up to a \$2,000 tax credit for high-efficiency heat pumps, driving demand for premium tech.

Energy Standards

2023 SEER2 mandates mean the "baseline" equipment today is far more complex and efficient than five years ago.

Chemical Regulations

The phase-out of R-410A for lower-global-warming R-32 refrigerants requires contractors to invest in entirely new tools and training.

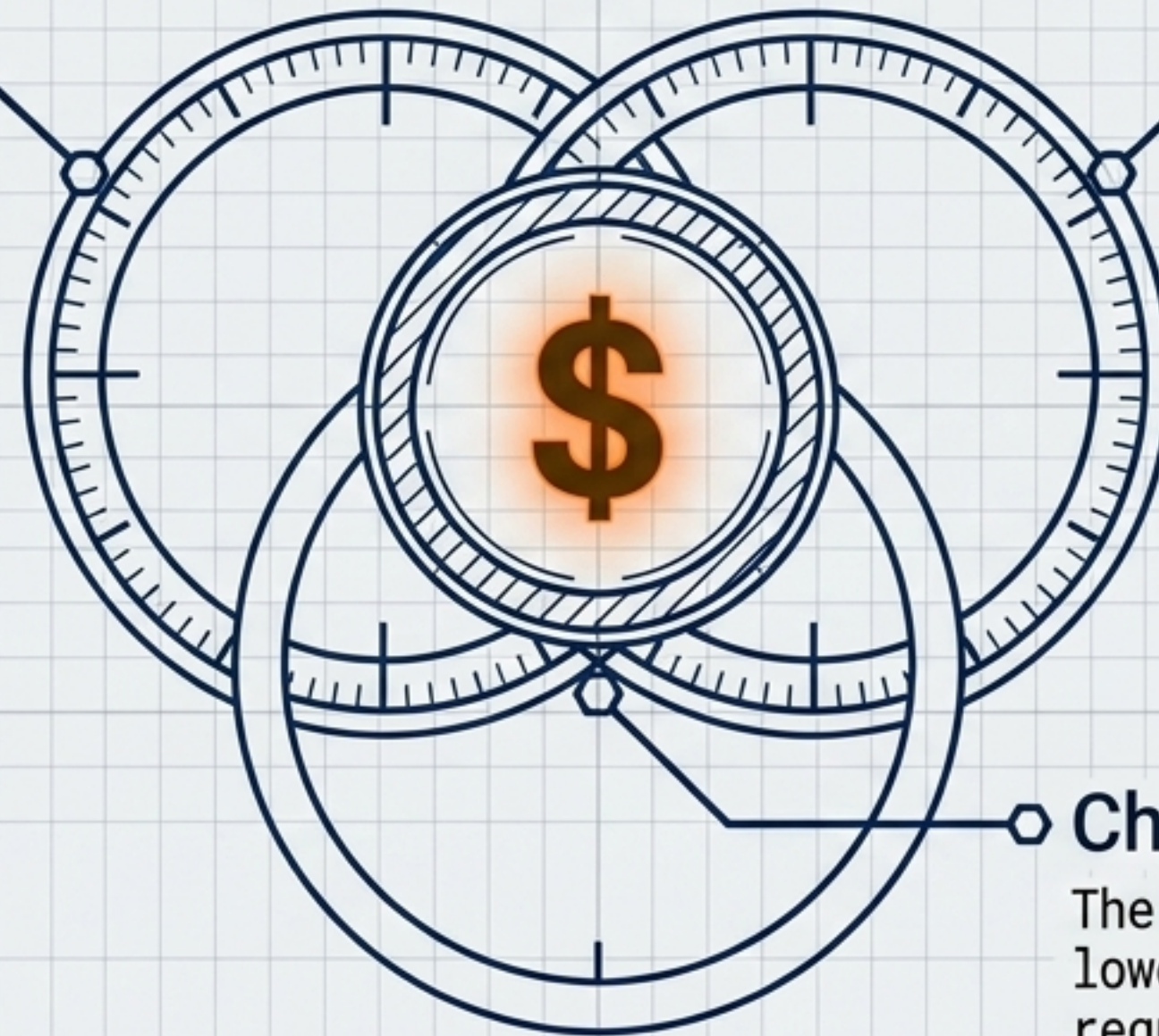

Budgeting Note: The NAHB recommends adding a 10-15% contingency to your renovation budget.

Evaluate four specific warning signs before committing to a full system replacement.

Age

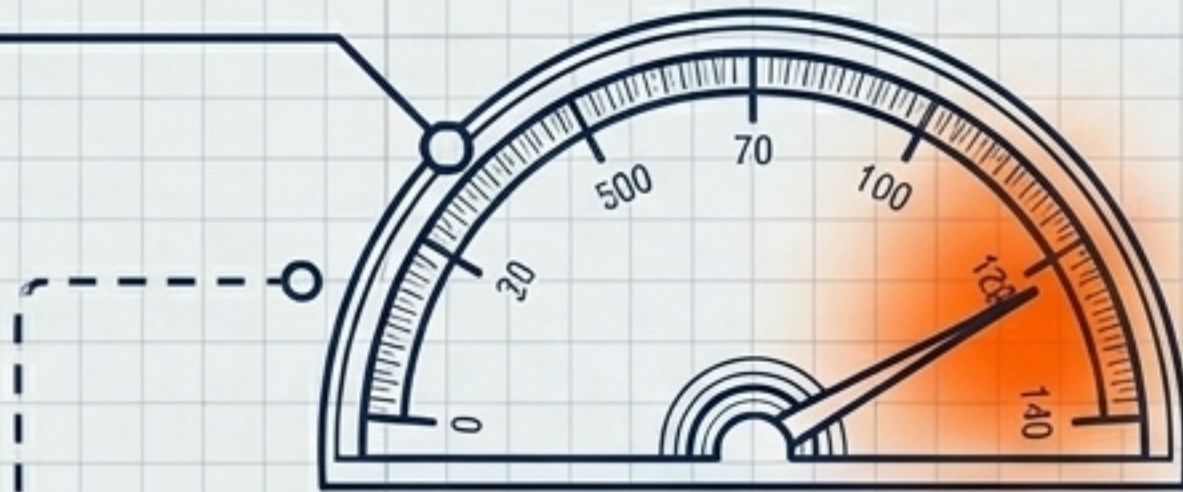

-- The system is over 15 years old (running on borrowed time).

Repair Costs

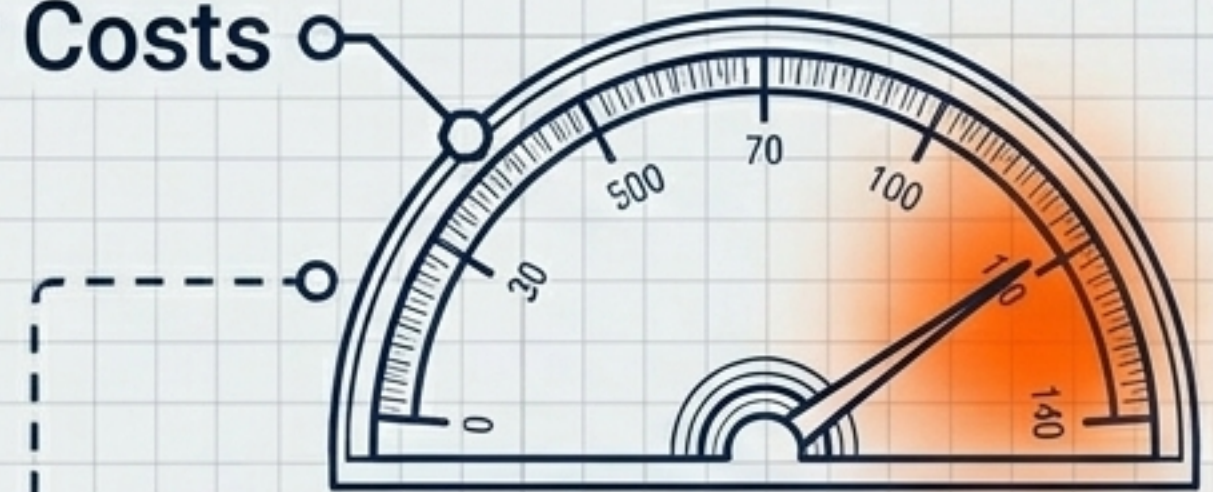

You face a single repair exceeding \$1,500, or call for service more than once a year.

Efficiency Drop

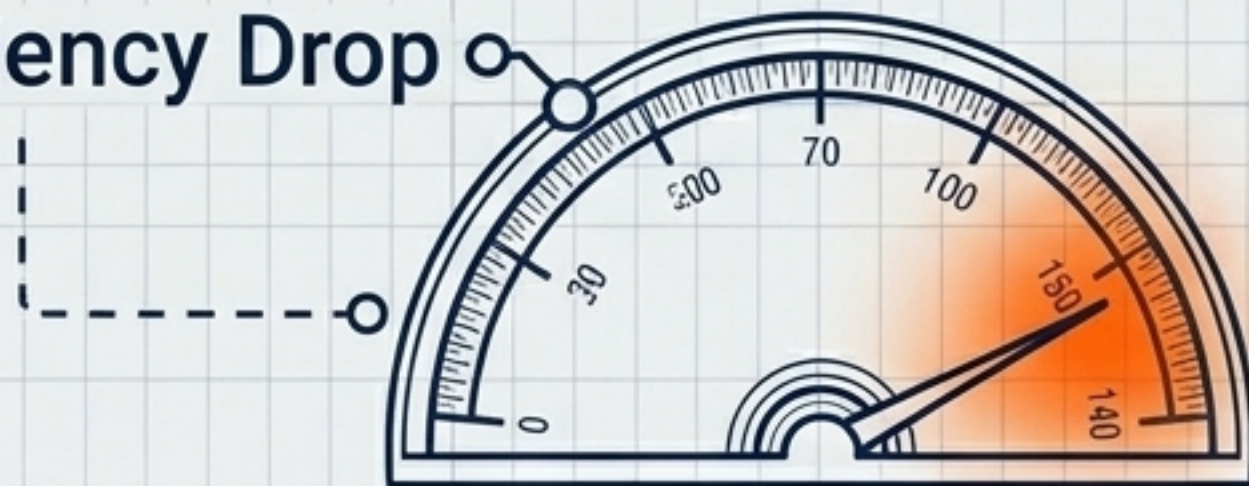

Sharp, unexplained increases in your monthly energy bills.

Performance Failure

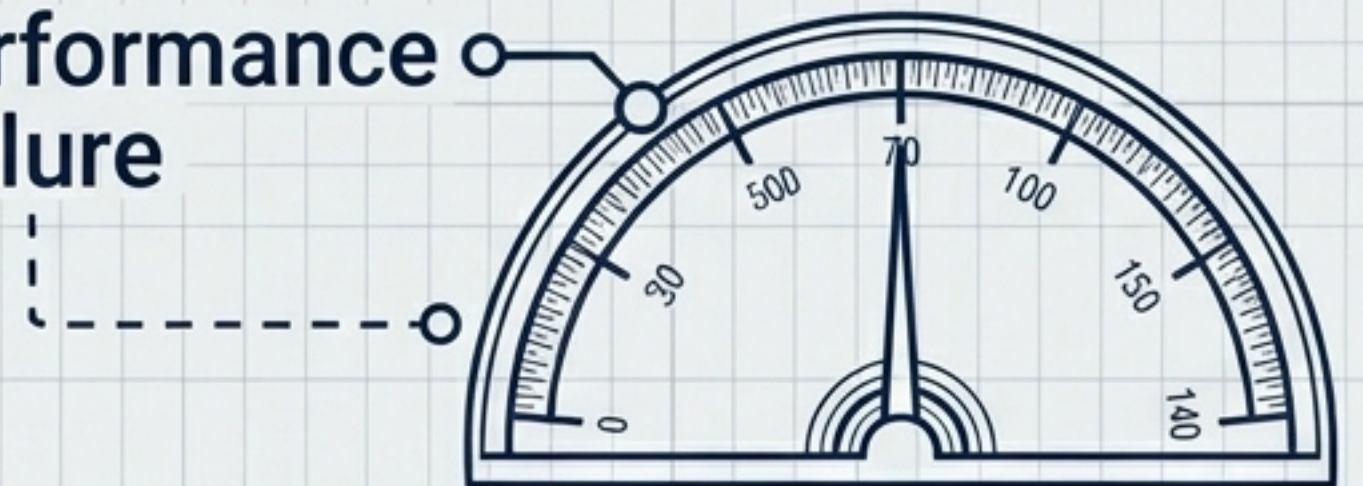

Excessive noise, declining indoor air quality, or inability to maintain set temperatures.

Protect your investment by evaluating contractors with three non-negotiable questions.

Diagnostic Table

The Question	The Hidden Risk	The Green Flag
Can you show me the Manual J load calculation?	Incorrectly sizing the system based purely on square footage rather than windows and insulation.	✓ Here is the report showing your home's specific heating and cooling load.
What are the specific model numbers and efficiency ratings?	Hidden downgrades or inability to make true apples-to-apples quote comparisons.	✓ We are quoting the Carrier 25VNA8... Here are the spec sheets showing 18.0 SEER2.
What does your installation warranty cover for labor?	Manufacturer parts warranties are useless if the initial installation fails.	✓ We provide a comprehensive two-year labor warranty written into our contract.

Shift your focus from debating equipment brands to finding an installation master.

The Old Way

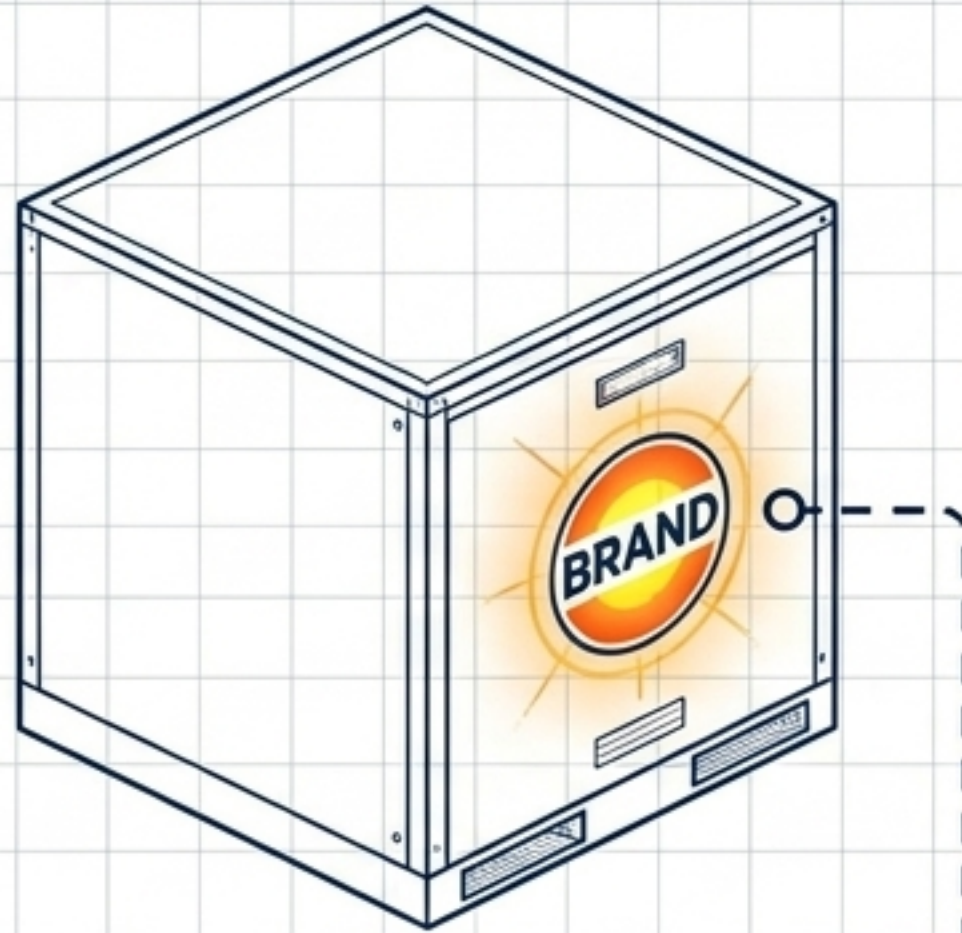

Focusing on the brand name. Treating it like a commodity.

The New Way

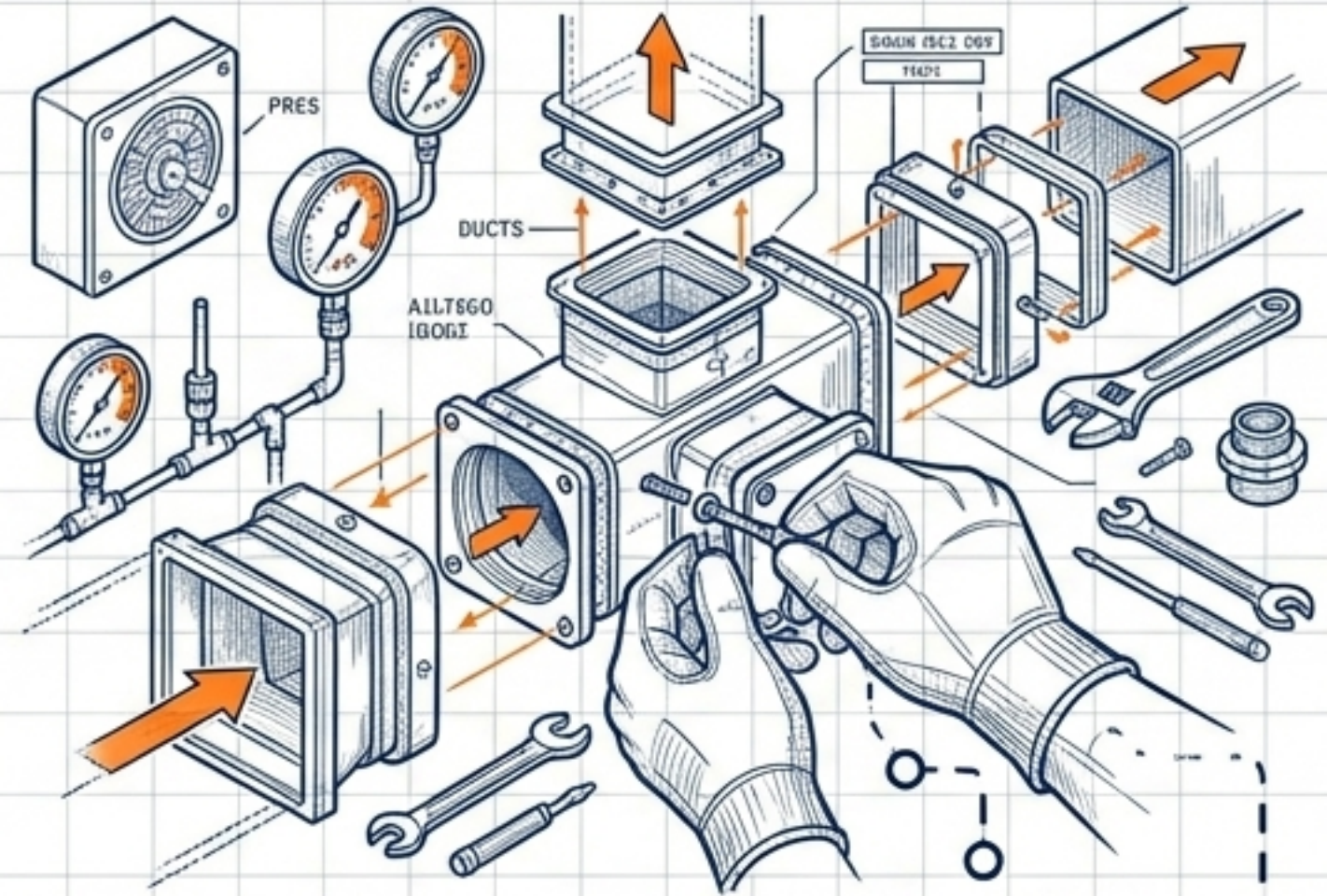

Focusing on the contractor. Treating it as a custom mechanical system.

The Renology Take: A perfectly installed entry-level system will always outperform a poorly installed top-of-the-line one.

The Final Rule: True value is found in the contractor who insists on load calculations, perfect airflow, and a written labor warranty.